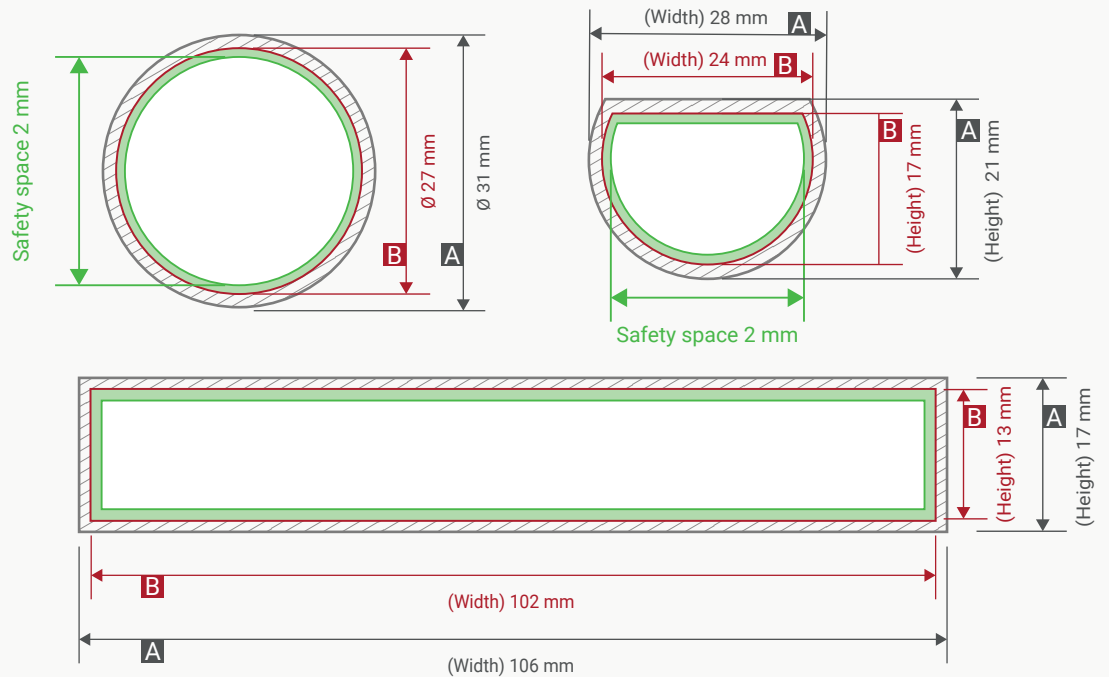

**Jar white 5 ml**

**A** = data format, incl. bleed

**B** = final format, after cut

**IMPORTANT INFORMATION**

Below you will find an overview of what you need to consider when creating print data (final format & data format). Please adhere to the specifications in order to achieve an optimal print result.

**FILE TYPES**

- The following file types are accepted: ai, eps, pdf, psd

**PRINT MARKS**

- Do not use any print marks in your file, e.g. folding, cutting, punching or register marks.

**DATA FORMAT AND BLEED**

- Send us your print data in the dimensions of the data format.
- Create your design in the dimensions of the final format.
- Please also note the safety margin for text and objects. This is 2 mm to each side of the final format.
- Please remember to create a cutting contour: To do this, create a new CMYK color with the name "CutContour".

**FONTS AND LINES**

- Convert all fonts into paths or alternatively supply the font.
- To ensure good legibility of your print product, do not use font sizes smaller than 4 pt (1.0 mm).
- Positive lines (dark line on light background) must have a thickness of at least 0.2 pt (0.07 mm).
- Negative lines (light line on dark background) must be at least 0.5 pt (0.18 mm) thick

**RESOLUTION**

- Ensure a good resolution when integrating images or graphics. For a good result, this should be at least 300 dpi.

**FILE NAMING**

- Please name your print files clearly and indicate the SK UV gel article number for which the label is intended.

**BATCH NUMBER**

- The batch number is welded into the top of the seam on our tubes. If the batch number is also to be shown on the label, a placeholder must be created for this.

**LAMINATION**

- Liquid laminations are available in matt or glossy on request.
- ATTENTION:** Matt laminate tends to form stripes. This is a normal process and is not a reason for complaint.

**FOILS/MATERIAL**

- We offer the following films for your labels:
  - matt/white
  - glossy/white
  - glossy/transparent
- All films have a thickness of 100  $\mu$

**DISCLAIMER**

- We accept no liability for non-compliance with the printing guidelines. Print approval is always given by the customer.
- Unless otherwise agreed, we also accept no liability for the following errors:
  - incorrect or missing ingredients
  - incorrect or missing hazard symbols
  - illegible/too small fonts
  - poor contrast
  - blurred images
  - spelling mistakes

 Download  
template

## Jar white 15 ml

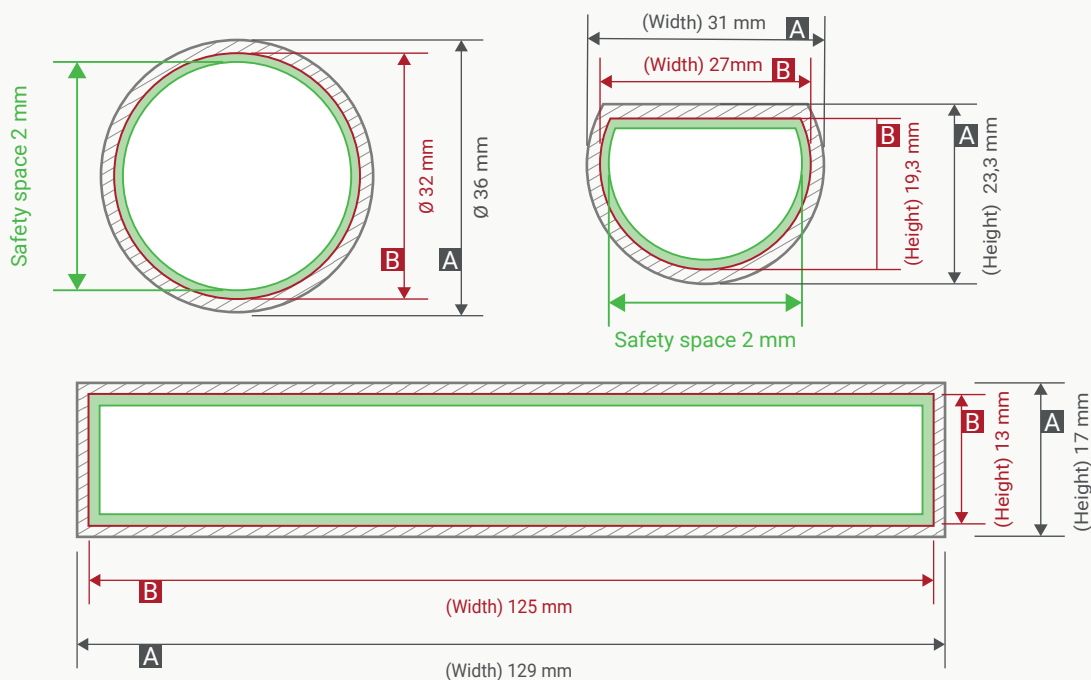

**A** = data format, incl. bleed

**B** = final format, after cut

### IMPORTANT INFORMATION

Below you will find an overview of what you need to consider when creating print data (final format & data format). Please adhere to the specifications in order to achieve an optimal print result.

#### FILE TYPES

- The following file types are accepted: ai, eps, pdf, psd

#### PRINT MARKS

- Do not use any print marks in your file, e.g. folding, cutting, punching or register marks.

#### DATA FORMAT AND BLEED

- Send us your print data in the dimensions of the data format.
- Create your design in the dimensions of the final format.
- Please also note the safety margin for text and objects. This is 2 mm to each side of the final format.
- Please remember to create a cutting contour: To do this, create a new CMYK color with the name "CutContour".

#### FONTS AND LINES

- Convert all fonts into paths or alternatively supply the font.
- To ensure good legibility of your print product, do not use font sizes smaller than 4 pt (1.0 mm).
- Positive lines (dark line on light background) must have a thickness of at least 0.2 pt (0.07 mm).
- Negative lines (light line on dark background) must be at least 0.5 pt (0.18 mm) thick

#### RESOLUTION

- Ensure a good resolution when integrating images or graphics. For a good result, this should be at least 300 dpi.

#### FILE NAMING

- Please name your print files clearly and indicate the SK UV gel article number for which the label is intended.

#### BATCH NUMBER

- The batch number is welded into the top of the seam on our tubes. If the batch number is also to be shown on the label, a placeholder must be created for this.

#### LAMINATION

- Liquid laminations are available in matt or glossy on request.
- ATTENTION: Matt laminate tends to form stripes. This is a normal process and is not a reason for complaint.

#### FOILS/MATERIAL

- We offer the following films for your labels:
- matt/white
- glossy/white
- glossy/transparent
- All films have a thickness of 100  $\mu$

#### DISCLAIMER

- We accept no liability for non-compliance with the printing guidelines. Print approval is always given by the customer.
- Unless otherwise agreed, we also accept no liability for the following errors:
  - incorrect or missing ingredients
  - incorrect or missing hazard symbols
  - illegible/too small fonts
  - poor contrast
  - blurred images
  - spelling mistakes

Download  
template



## Jar white 30 ml

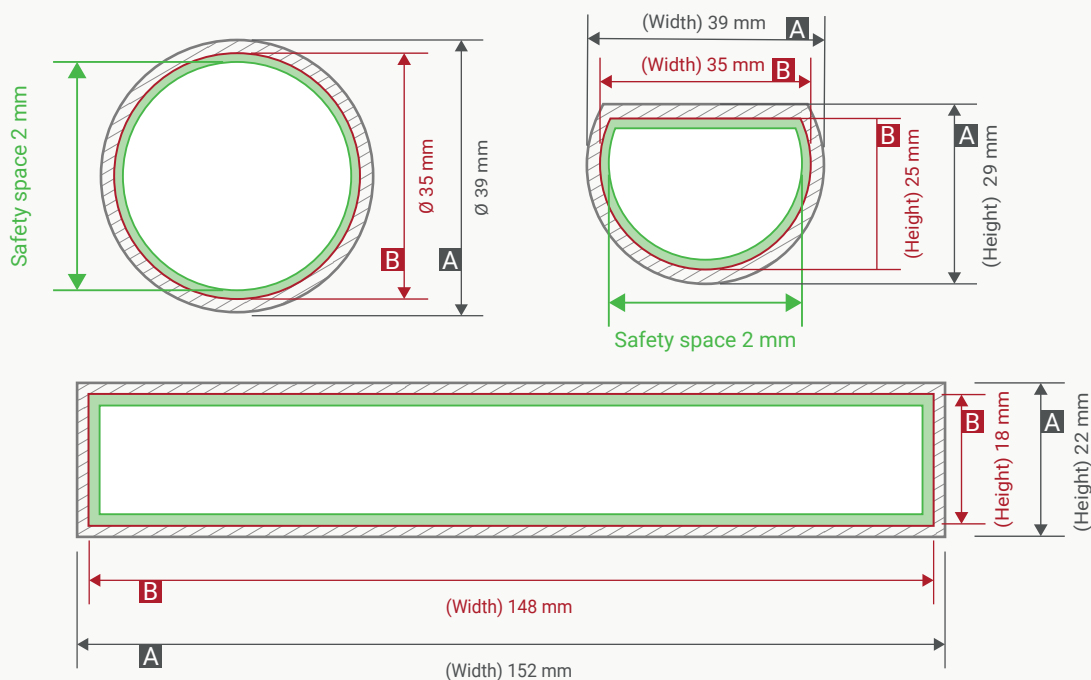

**A** = data format, incl. bleed

**B** = final format, after cut

### IMPORTANT INFORMATION

Below you will find an overview of what you need to consider when creating print data (final format & data format). Please adhere to the specifications in order to achieve an optimal print result.

#### FILE TYPES

- The following file types are accepted: ai, eps, pdf, psd

#### PRINT MARKS

- Do not use any print marks in your file, e.g. folding, cutting, punching or register marks.

#### DATA FORMAT AND BLEED

- Send us your print data in the dimensions of the data format.
- Create your design in the dimensions of the final format.
- Please also note the safety margin for text and objects. This is 2 mm to each side of the final format.
- Please remember to create a cutting contour: To do this, create a new CMYK color with the name "CutContour".

#### FONTS AND LINES

- Convert all fonts into paths or alternatively supply the font.
- To ensure good legibility of your print product, do not use font sizes smaller than 4 pt (1.0 mm).
- Positive lines (dark line on light background) must have a thickness of at least 0.2 pt (0.07 mm).
- Negative lines (light line on dark background) must be at least 0.5 pt (0.18 mm) thick

#### RESOLUTION

- Ensure a good resolution when integrating images or graphics. For a good result, this should be at least 300 dpi.

#### FILE NAMING

- Please name your print files clearly and indicate the SK UV gel article number for which the label is intended.

#### BATCH NUMBER

- The batch number is welded into the top of the seam on our tubes. If the batch number is also to be shown on the label, a placeholder must be created for this.

#### LAMINATION

- Liquid laminations are available in matt or glossy on request.
- ATTENTION: Matt laminate tends to form stripes. This is a normal process and is not a reason for complaint.

#### FOILS/MATERIAL

- We offer the following films for your labels:
- matt/white
- glossy/white
- glossy/transparent
- All films have a thickness of 100  $\mu$

#### DISCLAIMER

- We accept no liability for non-compliance with the printing guidelines. Print approval is always given by the customer.
- Unless otherwise agreed, we also accept no liability for the following errors:
  - incorrect or missing ingredients
  - incorrect or missing hazard symbols
  - illegible/too small fonts
  - poor contrast
  - blurred images
  - spelling mistakes

Download  
template



## Jar white 50 ml

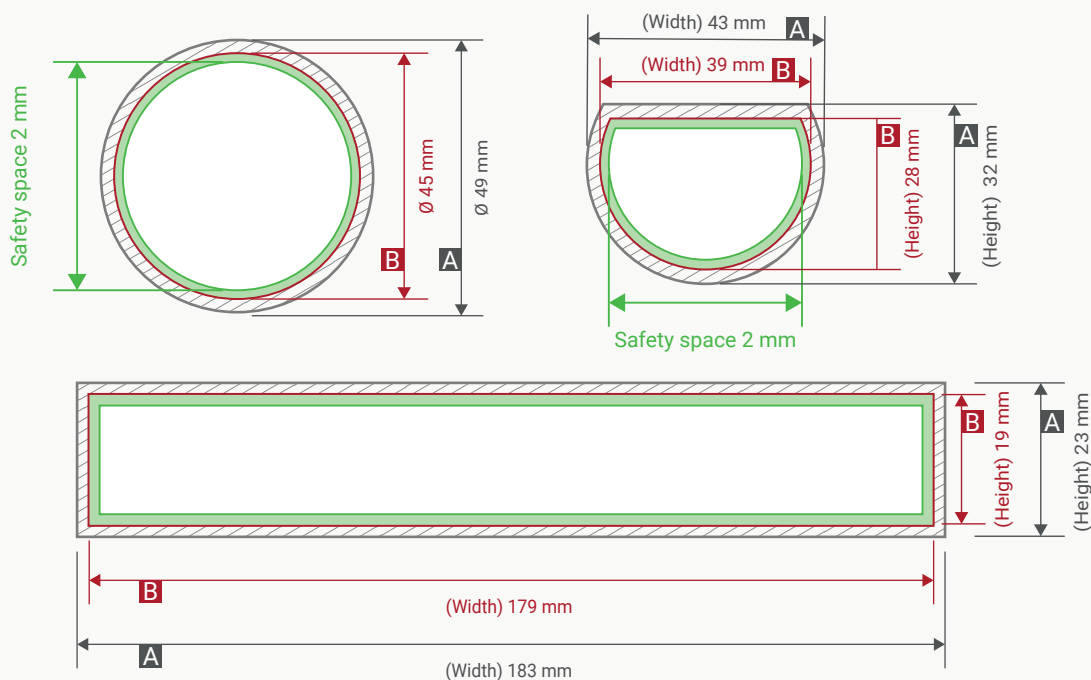

**A** = data format, incl. bleed

**B** = final format, after cut

### IMPORTANT INFORMATION

Below you will find an overview of what you need to consider when creating print data (final format & data format). Please adhere to the specifications in order to achieve an optimal print result.

#### FILE TYPES

- The following file types are accepted: ai, eps, pdf, psd

#### PRINT MARKS

- Do not use any print marks in your file, e.g. folding, cutting, punching or register marks.

#### DATA FORMAT AND BLEED

- Send us your print data in the dimensions of the data format.
- Create your design in the dimensions of the final format.
- Please also note the safety margin for text and objects. This is 2 mm to each side of the final format.
- Please remember to create a cutting contour: To do this, create a new CMYK color with the name "CutContour".

#### FONTS AND LINES

- Convert all fonts into paths or alternatively supply the font.
- To ensure good legibility of your print product, do not use font sizes smaller than 4 pt (1.0 mm).
- Positive lines (dark line on light background) must have a thickness of at least 0.2 pt (0.07 mm).
- Negative lines (light line on dark background) must be at least 0.5 pt (0.18 mm) thick

#### RESOLUTION

- Ensure a good resolution when integrating images or graphics. For a good result, this should be at least 300 dpi.

#### FILE NAMING

- Please name your print files clearly and indicate the SK UV gel article number for which the label is intended.

#### BATCH NUMBER

- The batch number is welded into the top of the seam on our tubes. If the batch number is also to be shown on the label, a placeholder must be created for this.

#### LAMINATION

- Liquid laminations are available in matt or glossy on request.
- ATTENTION: Matt laminate tends to form stripes. This is a normal process and is not a reason for complaint.

#### FOILS/MATERIAL

- We offer the following films for your labels:
- matt/white
- glossy/white
- glossy/transparent
- All films have a thickness of 100  $\mu$

#### DISCLAIMER

- We accept no liability for non-compliance with the printing guidelines. Print approval is always given by the customer.
- Unless otherwise agreed, we also accept no liability for the following errors:
  - incorrect or missing ingredients
  - incorrect or missing hazard symbols
  - illegible/too small fonts
  - poor contrast
  - blurred images
  - spelling mistakes

Download  
template

